

STRUCTURE

This system was built based on rich expertise in experimental optical research

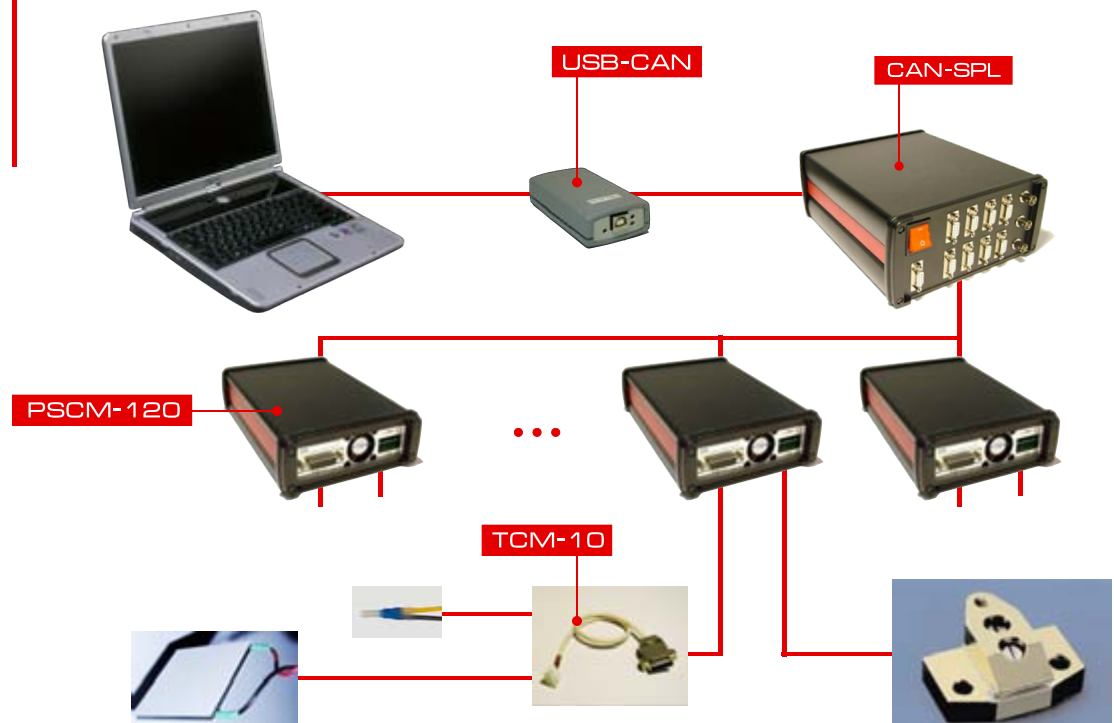

FUNCTION

CAN provide powering and data communication of the cooperative modules

A system of smart modules interconnected via noise-immune Controller Area Network (CAN) provides synchronous forming of highly stable pump current pulses for one or several laser diode bars and automatic maintenance of temperature for each bar.

The system provides different optical schemes of solid-state laser active component pumping

ESSENTIAL FEATURES

- synchronous operation of up to 32 laser diode bars
- forming of pumping current pulses with controlled amplitude (10...120 A) and duration (50...250 us)
- measurement of the absolute value of temperature for each laser diode bar with an accuracy of $\pm 0,1$ °C
- centralized operation mode management and diagnostics for each bar individually
- forming of engaging pulses for a Q-Switch driver and synchronization of other devices
- multistage protection of laser diode bars against damage during the operation
- allows building of a complex for automatic measurement of the parameters of laser radiation

APPLICATION

- development of new solid-state lasers
- investigation of radiation generation processes in solid-state lasers with pulse laser diode bar pumping
- analysis of properties and measurement of the parameters of laser radiation

SYSTEM ELEMENTS

Offers a good solution for an optical laboratory: a researcher can easily equip the experiment and test different optical pumping schemes

CAN - PC commutation module

- ISO-11898
- USB1.1/2.0



USB-CAN

+24V power supply and CAN splitter

- ISO-11898



CAN-SPL

Pumping current pulses forming and thermostating modules for laser diode bars

- ISO-11898



PSCM-120

Temperature logging module for laser diode bars



TCM-10

System control software

- Windows 2000
- Windows XP

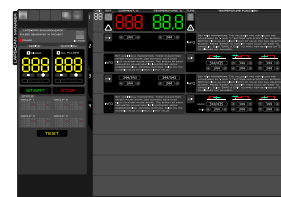

MCPS CONTROL

Options

- PTS-U0910 PSCM-120 and CAN-SPL connection cable
- PTS-U0915 Four PSCM-120 modules and CAN-SPL couple cable
- PTS-U0920 CAN-SPL and USB-CAN connection cable
- PTS-U0205 High-current cable with compensated inductance for the connection of PSCM-120 modules and laser diode bars

Easy connection of system modules can be provided using optional elements

USB-CAN

Galvanic isolation
between CAN and PC

CAN-PC commutation module



CAN connection
cable can be several
tens of meters long

The module provides bidirectional data transmission between CAN (ISO-11898) and USB interface v1.1/2.0

USB-CAN - module performance figures

Breakdown voltage of the galvanic isolation circuit, V	1000
Allowable ambient temperatures, C	-25...+40
Overall dimensions, mm ³ (WxHxL)	80x45x20
Weight, kg	0,1

CAN-SPL

CAN splitter and power supply



CAN-SPL module provides simultaneous operation of up to 32 PSCM-120 modules while using PTS-U0915 connection cable or 8 modules while using PTS-U0910 cables.

The internal synchronizer forms on its outputs:

- lockout pulse, which rise-up portion corresponds to the PSCM-120 module current pulse rise-up portion
- engaging pulse for an Q-switch driver, whose time delay with respect to the lockout pulse is set by the software.

Autonomous mode of operation is foreseen for the synchronizer, which provides generation of the pumping current pulse of the laser diode bar on arrival of external initiation pulse on its input.

Main characteristics

Supply main voltage, V	180...240
Maximum power consumption, W	750
Power supply efficiency, not less than	0,9
Power supply output voltage, V	24±10%
Allowable ambient temperature, C	-25...+40
Overall dimensions, mm ³ (WxHxL)	190x90x225
Weight, kg	2,1

Synchronizer characteristics

Polarity of an external driver pulse	negative
Effective input resistance, kOhm	1,0
Minimum/maximum of the external pulse driver amplitude, V	1/5
Output pulse polarity	negative
Output pulse length, us	10
Minimum load resistance, Ohm	50
Programmable time delay between the edge of the pulse generated by the Q-switch's driver and the rise-up portion of the laser diode bar's pumping current pulse, us	50...500
Temporal resolution of the delay of the Q-switch's output driver pulse	2

PSCM-120

Module for forming of pulses of pumping current and thermostating of laser diode bars



The module provides:

- protection against short circuits in the output circuit
- protection against forming of the pumping current pulses whose length exceeds the safe limit
- protection of the laser diode bar against overheating and condensation - pumping terminates automatically if the temperature goes out of the safe range
- a "soft start" system of a module's internal power supply
- laser diode bar protection against current forming in case of any damage in the module subsystem

Functional scheme

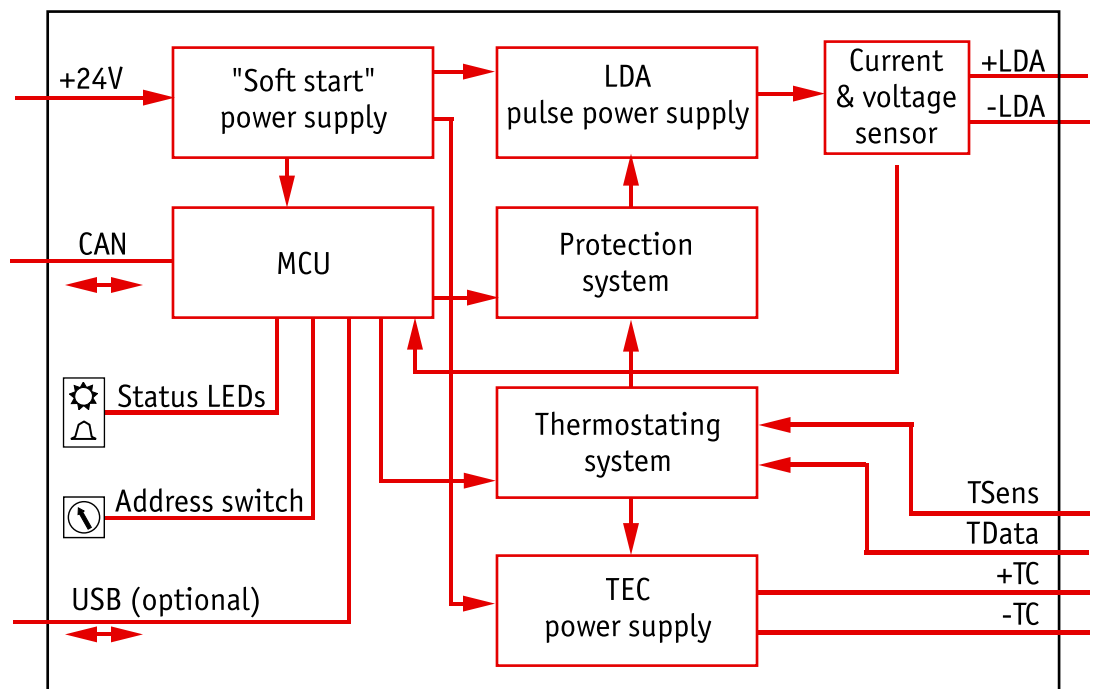

PSCM-120 - main characteristics

Amplitude of the pumping current pulse, A	10...120
Maximum voltage on the module output corresponding to the maximum amplitude of a pumping current pulses, V	3,5
Pumping current pulse duration, us	50...250*
Pumping current pulse period, ms	20...1000
Minimum duty cycle of a pumping current pulses when their amplitude is maximal	70
Pumping current pulse edge duration (while using PTS-U0205 connection cable with compensated inductance), not more than, us	30
Long-time stability of the pumping current pulses amplitude in case of maximum change of the ambient temperature, not more than, %	± 3
Long-time stability of the pumping current pulse's amplitude in case of ±2°C change of the ambient temperature, not more than, %	± 1,5
Resolution of the amplitude of a pumping current pulse, A	1
Resolution of the duration of a pumping current pulse, us	2
Pumping current pulses period, ms	1

* 50...500 us optional

PSCM-120 - thermostating system characteristics

Operating temperature range of a laser diode bar, °C	+15...+35
Error of automatic regulation of the laser diode bar's operating temperature, °C	± 0,05
Long-time instability of the operating temperature of a laser diode bar working with TCM-10 module, °C	± 0,1
Maximum electrical power on the TEC's input, W	12
Thermo electric cooler's maximum current, A	1,6
Resolution of the operating temperature of a laser diode bar, °C	0,1

PSCM-120 - performance figures

Coefficient of efficiency, not less than*	0,8
Allowable ambient temperature, °C	-25...+40
Overall dimensions, mm3 (WxHxL)	125x50x170
Weight, kg	0,6

*at the maximum amplitude of the pumping current pulses, their minimum duty cycle and maximum TEC current

PSCM-120 - Pumping current pulses oscillograms

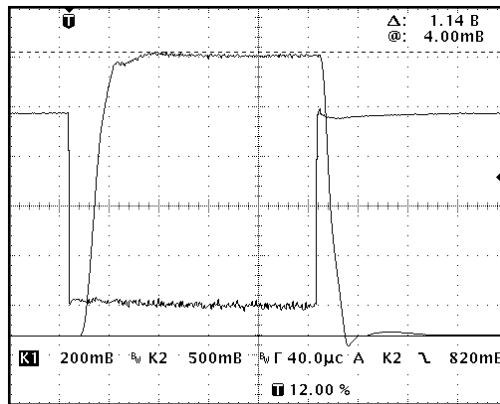

a

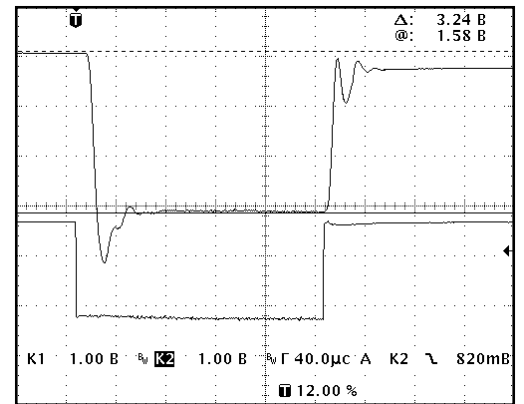

b

Pumping current pulse (a) and voltage pulse registered in a laser diode bar (b)

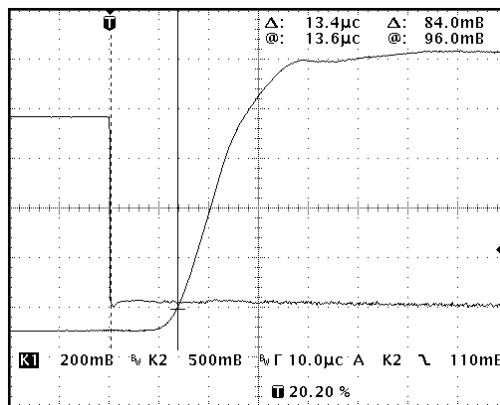

a

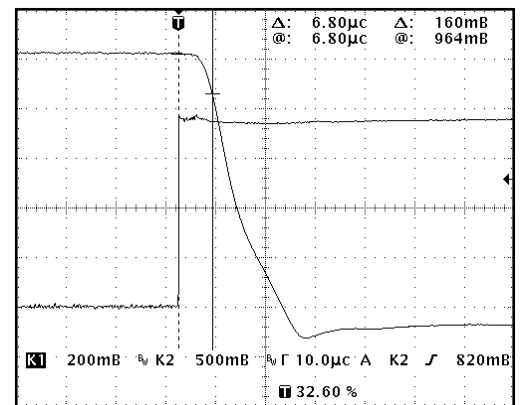

b

Rise (a) and fall (b) of the pumping current pulse

TCM-10

Laser diode bar's temperature logging module

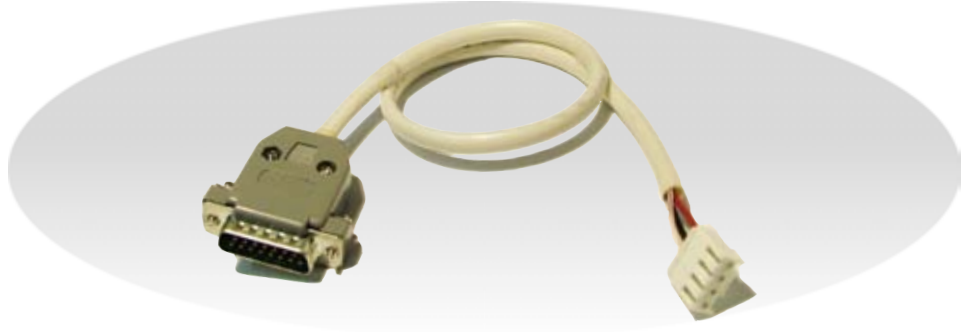

The module is designed for laser diode bar's temperature logging with an absolute error of $\pm 0,1^{\circ}\text{C}$. It contains a high-stability precision resistor, which requires calibration only once a year, and a module with FLASH-memory, which stores calibration coefficients and parameters of the thermostabilization system.